

# Jamesbury® Wafer-Sphere® High-performance butterfly valves

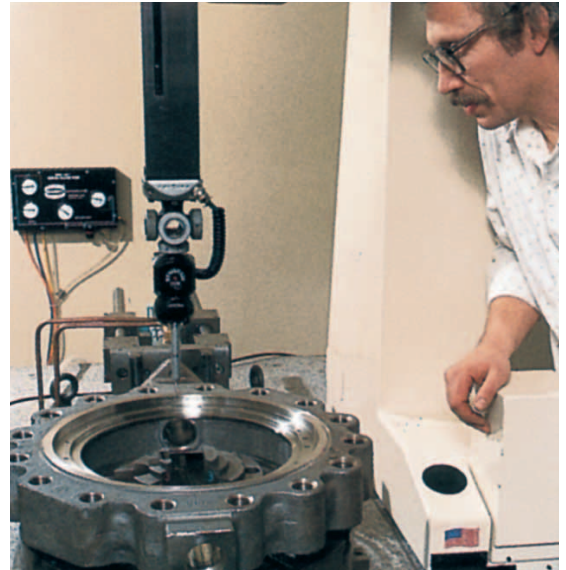

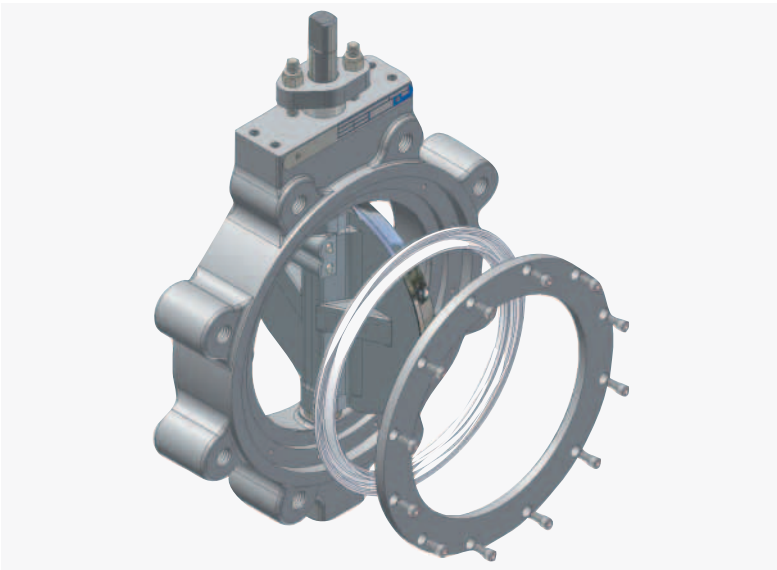

## Why *Wafer-Sphere* high-performance butterfly valves?

*Jamesbury* brand valves have always been recognized leaders in valve technology. For nearly 50 years, their unique features have been field-proven to provide trouble-free shut-off in thousands of applications just like yours. This experience allows us to provide a butterfly valve that can lower your costs without risking performance.

Our *Wafer-Sphere* high-performance butterfly valve combines a special off-center disc with proprietary seat designs and revolutionary Xtreme® sealing technology to provide you with the tightest-sealing, longest-lasting, lowest-cost alternative to gate valves, as well as to other heavier, rotary-type valves.

Since their cycle life is far greater than a traditional butterfly valve, *Wafer-Sphere* high-performance butterfly valves are often a more cost-effective solution even for applications without high-performance service demands.

They are especially suitable for applications in grain/corn processing, chemicals, petrochemicals, power, refining, steel, air separation, HVAC and more.

### *Wafer-Sphere*

- High-Performance Butterfly Valves
- Flexible lip seats and eccentric disc resist erosion and wear.
- Total costs are comparatively lower as valve size increases.
- Simple tightening of the valve gland packing stops leakage.
- Actuators easily accept limit switches and positioners.

### Gate Valves

- Metal wedge and seats are prone to wear and erosion.
- Significant manpower hours are required to install and repair.
- Time-consuming maintenance requires full disassembly.
- Special yokes or other devices are needed for actuation.



# Wafer-Sphere

## A closer look

Nothing compares when you take a close look at *Wafer-Sphere* butterfly valves. See for yourself what makes it the most preferred brand of high-performance butterfly valve.

### Performance Advantages Over Ordinary Valves

Compared with traditional butterfly valves and many other valve types, *Wafer-Sphere* butterfly valves deliver several unique benefits.

#### High Pressure Ratings

*Jamesbury*® high-performance butterfly valves are rated at ANSI 150, 300 and 600 pressure classes. They offer proven reliability in applications ranging from vacuum to very high pressure.

#### Application Range

*Wafer-Sphere* designs and materials can handle a broad range of services.

#### Wide Temperature Range

With *Xtreme* sealing materials, *Wafer-Sphere* butterfly valves are fully rated to replace costlier valves in cryogenic (-320°F) to high-temperature (500°F) applications.

#### Easy Automation

Like traditional butterfly valves, *Wafer-Sphere* high-performance butterfly valves are always easier to automate than gate valves, and often easier to automate than other rotary valves.

#### A Low-Cost Environmental Solution

With Emission-Pak® assemblies and our unique, retrofittable stem sealing device, *Wafer-Sphere* valves can easily be adapted to comply with evolving emissions regulations.

#### Reliability

*Jamesbury* seats can provide reliability and tight shut-off under many damaging process conditions.

#### Lower Installed Cost and Higher Performance than Gate Valves

*Wafer-Sphere* high-performance butterfly valves are designed to replace gate valves in most applications, whether for easier automation or simply for lower cost and improved performance. This is truly one case where less is more.

#### Increased Safety Assurance

In difficult applications, like steam, the reliable, tight sealing of *Wafer-Sphere* high-performance butterfly valves reduces fugitive emissions.



### Features at a Glance

#### Positive Shaft Retention

Positive shaft retention prevents movement of the shaft past the compression plate.

#### Positive Shut-Off

Flexible-lip polymeric seat assures positive shut-off, compensating for wear to extend life.

#### Easy Maintenance

Only the insert needs to be removed to replace the seat. The insert and seat are self-aligning.

#### Fire-Tite® Sealing

*Wafer-Sphere Fire-Tite* valves meet the requirements of API 607, 4th edition with a secondary metal seat that ensures tight sealing before, during and after a fire.

#### Low Torque Requirements

Low output torque requirements allow the use of less costly actuators.

#### Wide Pressure Range

Available in 150 lb. (Series 815), 300 lb. (Series 830), and 600 lb. (Series 860) pressure classes — in wafer and in single-flanged lugged designs.

#### Broad Range of Materials

Available in a broad range of materials for standard and special services including chlorine, oxygen, cryogenics and vacuum.



## Wafer-Sphere high-performance butterfly valves

# Tighter, more reliable sealing

What turns an ordinary butterfly valve into a high-performance butterfly valve? It begins with an offset shaft and eccentric disc arrangement. This double offset design transmits a camming action to the disc and swings the disc completely away from the seat. Conventional butterfly valves do not have this feature. This design eliminates wear points around the disc at the top and bottom of the seat, as well as the resulting beading, scuffing, and ultimate tearing and leakage. When closed, the disc cams tightly into its seat to create a dependable tight seal.

### Double Offset Design

The unique sealing system also incorporates a double eccentric disc and shaft design to further extend the effectiveness of the seat. This unique offset design transmits a camming action to the disc and swings the disc completely away from the seat, no jamming or squeegeeing. This design eliminates wear points around the disc at the top and bottom of the seat. When closed, the disc cams tightly into its seat to create a double-tight seal. The combination of the double-offset disc and the flexible-lip seat are especially effective in a full range of applications from high vacuum ( $1 \times 10^{-5}$  Torr) to 1480 psi (102.1 bar).

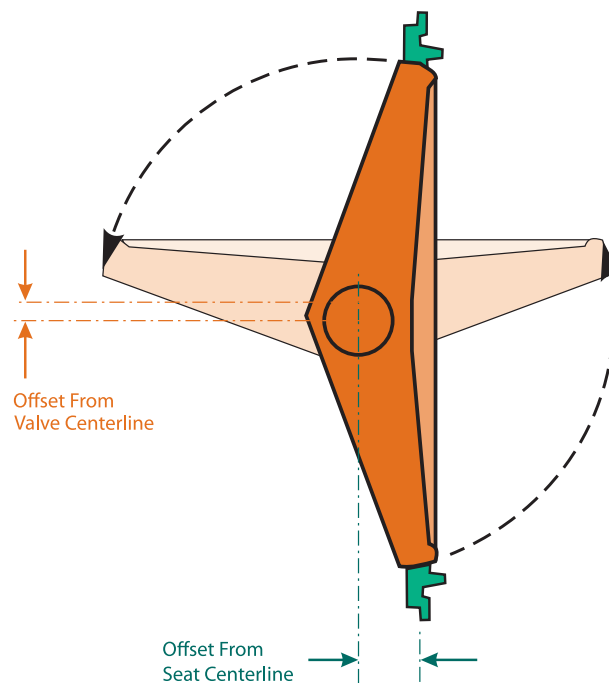

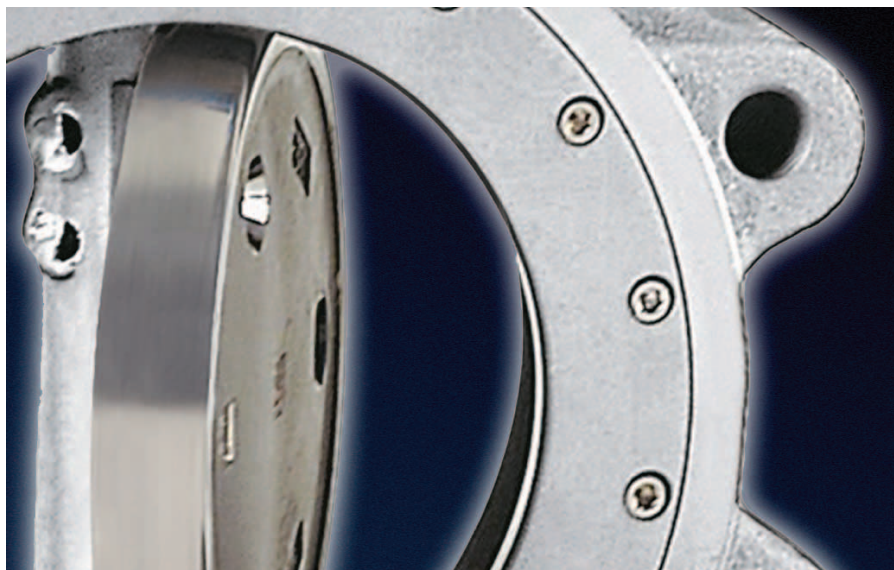

## Unique polymeric sealing provides trouble-free operation.

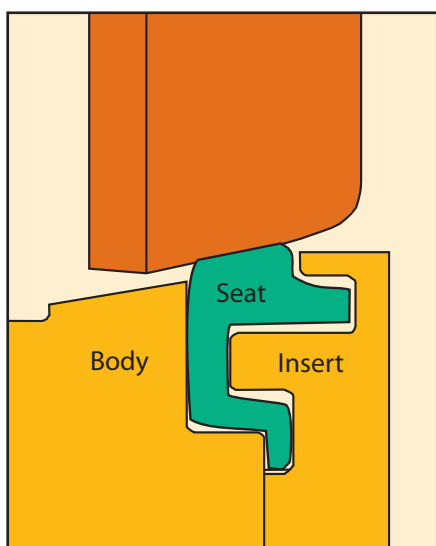

### Energized Seat

When the valve is shut, the disc slightly deflects and the seat “energizes.” While energized, the seat’s sealing surface is constantly pushing against the edge of the disc.

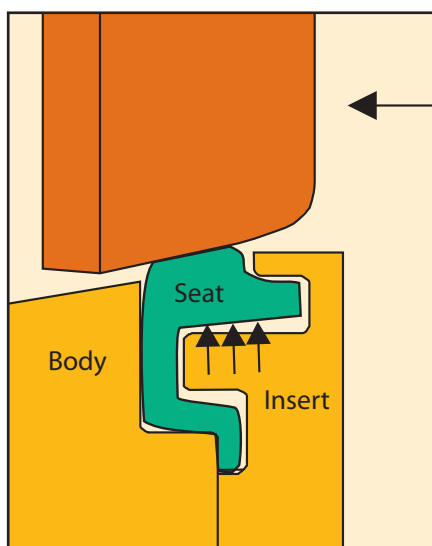

### Pressure on Insert Side

When pressure is on the insert side, pressure is applied under the seat lip, further amplifying the sealing force between the disc and the seat.

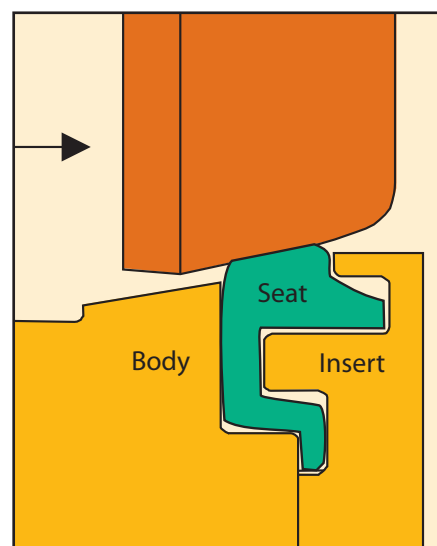

### Pressure on Non-Insert Side

When pressure is on the non-insert side, the disc moves into the seat. Due to the spherical profile of the disc, the more the disc moves into the seat, the tighter the shut-off. Excessive movement of the seat is limited by the flexible lip, which contacts the bottom of the grooves in the insert ring.

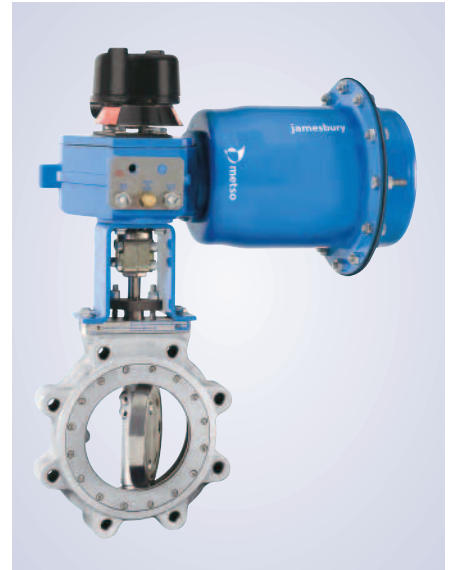
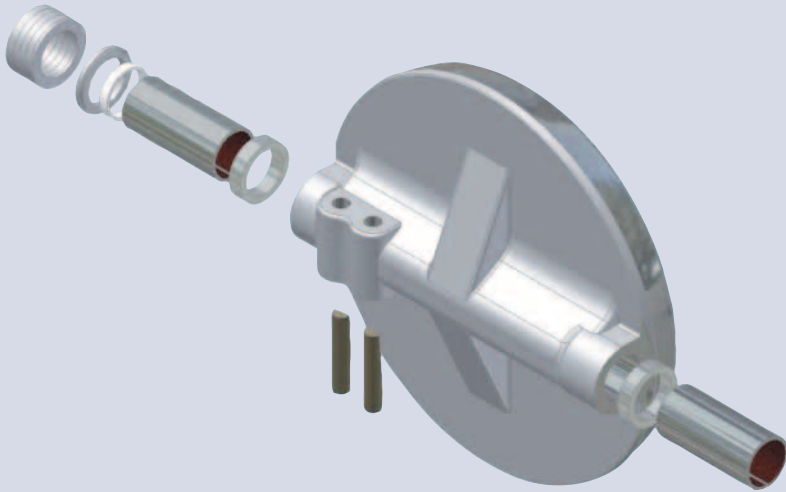

## Wafer-Sphere valves are equally suited to on-off and control applications.

Wafer-Sphere butterfly valves accommodate a variety of pneumatic and electric actuators for on-off service, as well as, pneumatic double-acting and spring-return actuators with positioners for control service. They offer superior control characteristics, wide rangeability, and an inherent flow characteristic that is modified equal percentage.

### Equally Suited to On-Off And Control Applications

Cv Factors for Series 815 and 830 Valves in Intermediate Positions

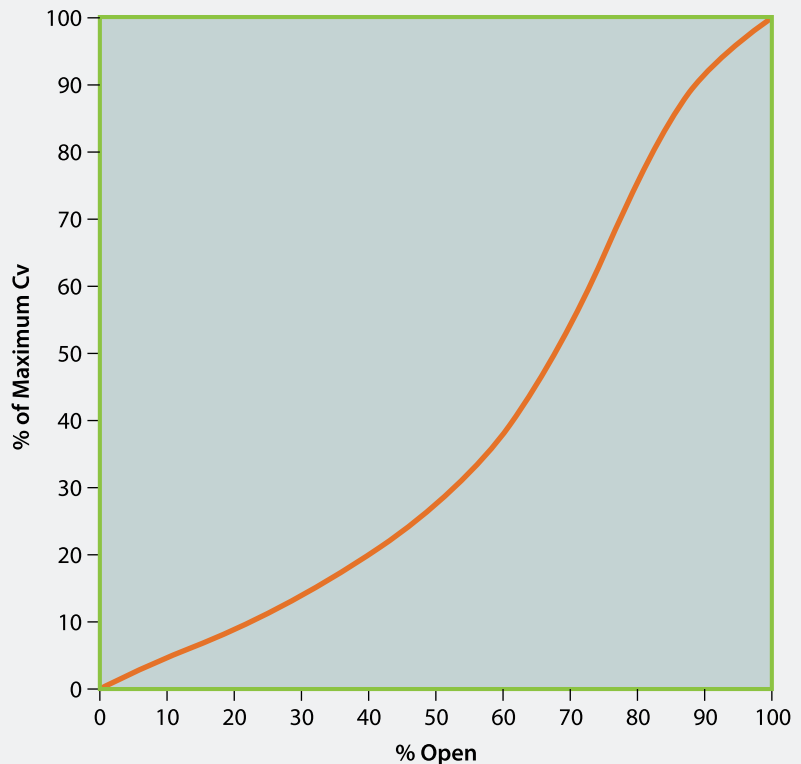



## Fire-Tite

# Providing extra reliability for critical applications

*Fire-Tite Wafer-Sphere* valves offer outstanding advantages in providing reliable operation under normal conditions as well as during a fire. They are specifically developed for use in such industries as petroleum refining and distribution, chemical, marine and others. The metal-seat ring effectively stops flow through the valve if the PTFE seat is destroyed in a fire. *Fire-Tite* valves meet the requirements of NACE and are qualified to API 607 Edition 4 and BS 6755.

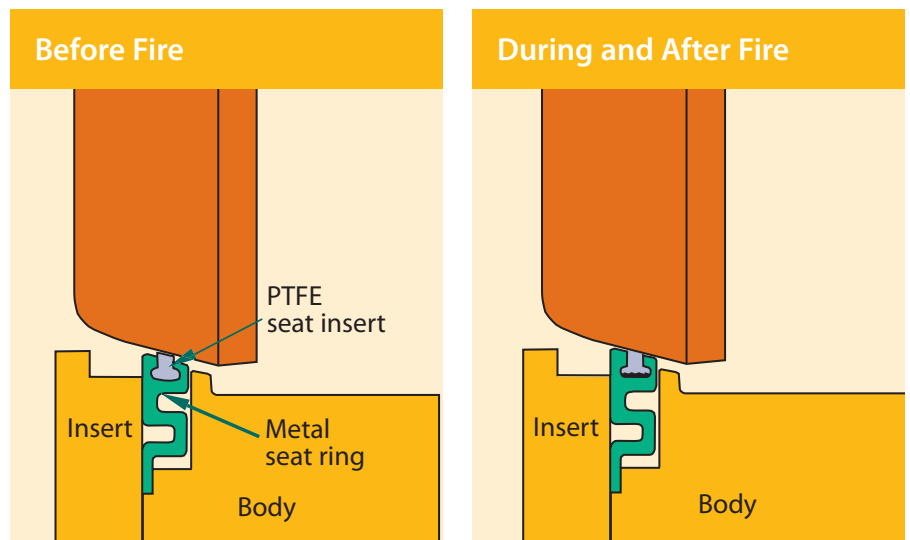

Metso products are qualified with intense cryogenic, fire, temperature and pressure testing in our engineering and development laboratories.



## Xtreme

# Expanding performance boundaries

When combined with our unique and application-proven seat designs, proprietary *Xtreme* seating materials broaden *Wafer-Sphere* butterfly valves' temperature and pressure applicability. With *Xtreme* seats, application temperatures range from  $-320^{\circ}\text{F}$  to  $500^{\circ}\text{F}$  and pressures up to 1480 psi. Low permeability characteristics and controlled crystallinity produce a valve seat which resists permanent distortion. This results in longer cycle life, better thermal cycle performance, and better pressure cycle capability.

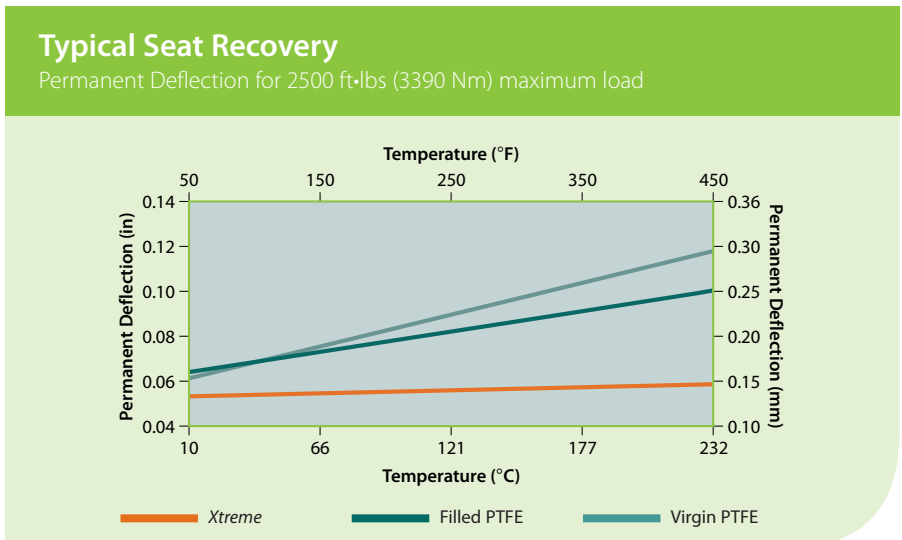
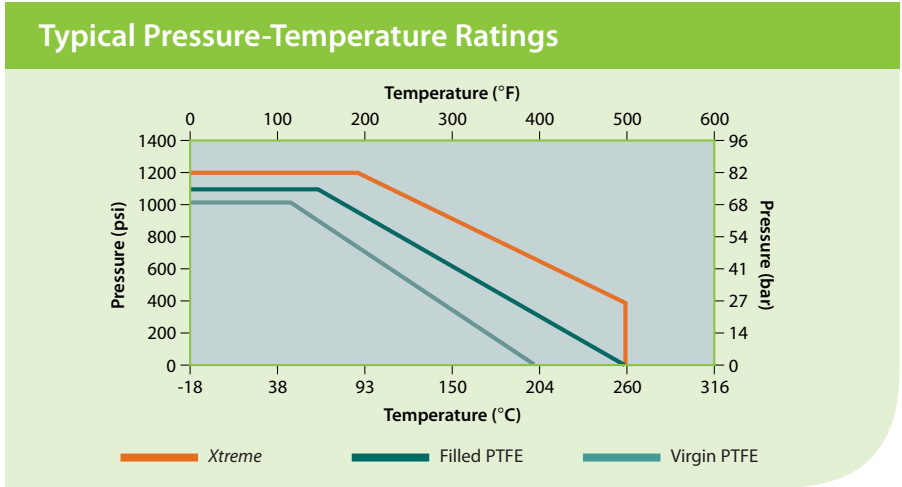

# Wafer-Sphere Special services

## Emission-Pak Live-Loaded Packing

When enhanced emissions control is needed to comply with evolving emissions standards, *Emission-Pak* live-loaded packing is available. The *Emission-Pak* live-loaded packing assembly includes PTFE V-ring packing live-loaded with disc spring washers for standard construction valves and graphite packing with Inconel disc springs for *Fire-Tite* valves to maintain a constant packing force without overcompression. It is available with new valves or as a retrofit kit for existing valves. Additional options, available with or without the *Emission-Pak* live-loaded packing, include double packing or double packing with monitoring port to facilitate testing of the primary seal and allow detection of a potential leak problem. Refer to the How to Order section at the end of this bulletin for specific ordering instructions. The operating torque of valves with *Emission-Pak* live-loaded packing will increase. (Refer to the torque equation in the Valve Torque Data section).

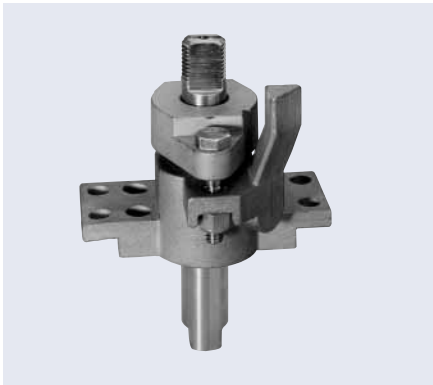

## Steam Service

*Wafer-Sphere* butterfly valves are well-suited for a wide range of steam applications. These range from PTFE-seated valves capable of handling lower pressure to valves with *Xtreme* seats. Ratings of *Wafer-Sphere* valves in this bulletin for on-off steam service are as follows: Valves may be derated based on shaft material selection.

## Cryogenic Service

Using *Wafer-Sphere* with unique polymeric and polymeric/ metal composite seats, cryogenic *Wafer-Sphere* valves are rated to give tight, reliable shutoff on service extending from -320°F (-196°C) to ambient condition at pressures up to 1440 psi (99 bar). Cryogenic seats for valve sizes 3" – 12" (DN 80 – 300) are composite. Seats for sizes 14" – 48" (DN 350 – 1200) are Kel-F® material. See Bulletin W130-1.

## Chlorine Service

*Wafer-Sphere* valves reliably control the flow of both liquid and gaseous chlorine. The patented seat design insures positive, leak-tight shutoff of this lethal substance. A range of key materials permits selection of the *Wafer-Sphere* valve best suited for the moisture content of the chlorine that is to be handled. Valves for chlorine service are specially cleaned to preclude possible reaction of the chlorine to foreign substances. For further information see Bulletin W150-2.

## Oxygen Service

*Wafer-Sphere* valves are available specially prepared for oxygen service, capable of filling a wide range of applications that include both on-off operation and proportional control. A rigid procedure is followed in preparing components, assembling, testing, and packaging these valves to assure cleanliness and to avoid the inherent danger of oxygen's reaction with grease, oil, or other foreign matter. Bulletin W150-3 contains additional details.

## NACE Service

ANSI Class 150 and 300 *Wafer-Sphere* valves are available to comply with the NACE MR0103 standard. These valves are well suited for oil and gas industry applications requiring sulfide stress cracking resistant metallic materials.

## Abrasive Service

For applications involving slurries or gas-borne solid particles, *Wafer-Sphere* valves are available with the disc hard-coated with tungsten titanium carbide (TTC). Service life of the valve is increased significantly with the assurance of extended sealing capability. This hard coating is also available on application on other valve components that may be subject to wear in other unusual process conditions.



## Vacuum Service



Standard *Wafer-Sphere* valves are rated for tight shut-off of vacuum to 2x10<sup>-2</sup> torr. Special high vacuum *Wafer-Sphere* valves can be provided for vacuums to 1x10<sup>-5</sup> torr. Additionally, high vacuum valves can be certified to have a leakage rate not to exceed 1x10<sup>-5</sup> cc/sec. of helium at 1x10<sup>-5</sup> torr vacuum. Refer to Bulletin W150-4 for details.

## High-Cycle Option

Testing in the *Jamesbury* R&D laboratories indicates that a combination of components, including *Xtreme* (X) seat, filled super PTFE shaft seals, 316 SS/Woven PTFE shaft bearings, PEEK®-filled PTFE thrust bearings and excluder rings, yields significantly longer life than a standard configuration valve. Actual cycle performance is subject to media, pressure, and temperature conditions. Applications such as oxygen, nitrogen, hydrogen, water, and other clean media are ideally suited for this option. Warning: Avoid any media containing acids or chemicals such as chlorine, bromine, sulfur dioxide, or steam, or temperatures that exceed 325°F (163°C).

	Sizes	Body Style	Max Press.	Max Temp.	Body/Trim Materials	Seat Materials	Bulletin
	<b>ANSI Class 150 Series 815 Butterfly Valves</b>						
	2 1/2 – 30" (65 – 750DN)	Wafer	285 psi 19.6 bar	500°F 260°C	Carbon Steel 316SS Alloy 20	Teflon® Xtreme UHMW	W101-6
	2 1/2 – 60" (65 – 1500DN)	Lugged			254SMO® Monel Hastelloy C		
	<b>ANSI Class 150 Series F815 Butterfly Valves</b>						
	3 – 30" (80 – 750DN)	Wafer	285 psi 19.6 bar	500°F 260°C	Carbon Steel 316SS Alloy 20	316SS/PTFE 316SS/XT	W101-6
	3 – 60" (80 – 1500DN)	Lugged			254SMO Monel Hastelloy C		
	<b>ANSI Class 300 Series 830 Butterfly Valves</b>						
	3 – 30" (80 – 750DN)	Wafer	740 psi 51 bar	500°F 260°C	Carbon Steel 316SS Alloy 20	Teflon Xtreme UHMW	W101-6
	3 – 36" (80 – 900DN)	Lugged			254SMO Monel Hastelloy C		
	<b>ANSI Class 300 Series F830 Butterfly Valves</b>						
	3 – 30" (80 – 750DN)	Wafer	740 psi 51 bar	500°F 260°C	Carbon Steel 316SS Alloy 20	316SS/PTFE 316SS/XT	W101-6
	3 – 36" (80 – 900DN)	Lugged			254SMO Monel Hastelloy C		
	<b>ANSI Class 600 Series 860 Butterfly Valves</b>						
	3 – 24" (80 – 600DN)	Wafer Lugged	1440 psi 99.3 bar	500°F 260°C	Carbon Steel 316SS	Xtreme	W104-1
	<b>ANSI Class 600 Series F860 Butterfly Valves</b>						
	3 – 24" (80 – 600DN)	Wafer Lugged	1440 psi 99.3 bar	500°F 260°C	Carbon Steel 316SS	316SS/PTFE	W104-1

	Sizes	Body Style	Max Press.	Max Temp.	Body/Trim Materials	Seat Materials	Bulletin
	<b>ANSI Class 150 Series 835 Butterfly Valves</b>						
	30 – 60" (750 – 1500DN)	Lugged	100 psi 6.9 bar	500°F 260°C	Carbon Steel 316SS Alloy 20 254SMO Monel Hastelloy C	Teflon <i>Xtreme</i>	W105-1
	<b>ANSI Class 150 Series F835 Butterfly Valves</b>						
	30 – 60" (750 – 1500DN)	Lugged	100 psi 6.9 bar	500°F 260°C	Carbon Steel 316SS Alloy 20 254SMO Monel Hastelloy C	316SS/PTFE	W105-1

	Sizes	Body Style	Max Press.	Temp. Range	Body/Trim Materials	Seat Materials	Bulletin
	<b>ANSI Class 150 Cryogenic Services Series K815 Butterfly Valves</b>						
	3 – 12" (80 – 300DN) 14 – 30" (350 – 750DN)	Wafer Lugged Wafer Lugged	275 psi 19 bar	-320 – +100°F -198 – 38°C	316SS Monel	316SS/PTFE  KEL-F	W130-1
	<b>ANSI Class 300 Cryogenic Services Series K830 Butterfly Valves</b>						
	<b>ANSI Class 300 Cryogenic Services Series K830 Butterfly Valves</b>						
	3 – 12" (80 – 300DN) 14 – 30" (350 – 750DN)	Wafer Lugged Wafer Lugged	720 psi 49.6 bar	-320 – +100°F -198 – 38°C	316SS Monel	316SS/PTFE  KEL-F	W130-1
	<b>ANSI Class 600 Cryogenic Services Series K860 Butterfly Valves</b>						
	3 – 12" (80 – 300DN)	Wafer Lugged	1440 psi 99.3 bar	-320 – +100°F -198 – 38°C	316SS Monel	316SS/PTFE	W130-1

### Corporate Office

Levytie 6, P.O. Box 310  
00811 Helsinki  
Finland  
Tel. +358 20 483 150, fax +358 20 483 151

### North America Corporate Office

44 Bowditch Drive, P.O. Box 8044  
Shrewsbury, Massachusetts, 01545-8044  
USA  
Tel. +1 508 852 0200, fax +1 508 852 8172

### Europe

6-8 rue du Maine  
68271 Wittenheim Cedex  
France  
Tel. +33 (0)3 89 50 64 00, fax +33 (0)3 89 50 64 40

### Latin America

Av. Independência, 2500-Iporanga  
18087-101, Sorocaba-São Paulo  
Brazil  
Tel. +55 15 2102 9700, fax +55 15 2102 9748/49

### Asia Pacific

238A Thomson Road  
#25-09 Novena Square Tower A  
307684 Singapore  
Tel. +65 6511 1011, fax +65 6250 083

### China

19/F, the Exchange Beijing, No. 118  
Jianguo Lu Yi, Chaoyang Dist  
100022 Beijing  
China  
Tel. +86-10-6566-6600, fax +86-10-6566-2575

### Middle East

Roundabout 8  
Unit AB-07, P.O. Box 17175  
Jebel Ali Freezone, Dubai  
United Arab Emirates  
Tel. +971 4 883 6974, fax +971 4 883 6836

For further information please contact  
one of our regional offices or visit our  
web site [www.metso.com/automation](http://www.metso.com/automation)

